



RTP1400 Blower with Internal Drive Brushless DC Motor



Service & Parts Manual

Part Number 150227-00
Motor Coach Industries
Part Number 16L-14-68CG

Rev. 7/2006

Contents

Chapter 1: Getting Started	
Product Description	1-2
About This Manual	1-2
Chapter 2: Recommended Maintenance	
Introduction	2-2
Chapter 3: Troubleshooting	
Introduction	3-2
Locked Impeller	3-2
Motor Not Operating	3-2
Obstruction	3-3
Over Temperature Shutdown	3-3
Under Voltage Shutdown	3-3
Chapter 4: Maintenance and Repair Procedures	
Introduction	4-2
Disassembling the Blower	4-2
Reassembling the Blower	4-4
Appendixes	
Appendix A: Replacement Parts List for the AMETEK MCI RTP1400 Blower	A-1
Appendix B: Specifications Outline Drawing for the AMETEK MCI RTP1400 Blower	B-1
Tables	
Table 3.1. Blower Performance (Unrestricted)	3-2
Figures	
Figure 3.1. Performance Curves for the AMETEK MCI RTP1400 Blower	3-4
Figure 4.1. Outline Drawing for the AMETK MCI RTP1400 Blower	4-3

Chapter 1: Getting Started

PRODUCT DESCRIPTION

Brushless DC impeller-style blowers offer multispeed aerodynamic performances for all types of high-airflow applications. The standard design comes with fully integrated electronics. The AMETEK Motor Coach Industries (MCI) RTP1400 Blower has an operating voltage of 27.6 VDC, a CFM of 620. The blower has two main components: a motor and a blower. A latch is included for installation purposes.

ABOUT THIS MANUAL

This manual provides step-by-step instructions and annotated diagrams for servicing the AMETEK MCI RTP1400 Blower. A parts list for the blower is provided in appendix A.

On the parts lists, each part is identified by part number, item number, quantity and description. The item numbers are used to annotate the schematic diagrams included in this manual (see, for example, figure 4.1 (p. 4-3). Circled numbers on the diagrams refer to the **item** numbers in the applicable parts list. For example:

4

refers to item number 4 (red impeller clamp) and part number 5-4012-6 on the blower replacement parts list (see appendix A).

3

refers to item number 3 (motor gasket) and part number 5-4012-5 on the blower replacement parts list (see appendix A).

These circled numbers also correspond to numbers in the maintenance procedures chapter (see chapter 4) of this manual. In the text of the steps, the item numbers are enclosed in flat brackets and follow the part name being referenced. For example:

inlet ring [6] refers to item number 6 on the blower replacement parts list (see appendix A).

When a notation such as (2x) appears with a part name on an annotated diagram, the number refers to the quantity of that particular part that is needed where indicated.

The remaining sections of this manual are as follows:

- Chapter 2: Recommended Maintenance
- Chapter 3: Troubleshooting
- Chapter 4: Maintenance and Repair Procedures
- Appendix A: Replacement Parts List for the AMETEK MCI RTP1400 Blower
- Appendix B: Specifications Outline Drawing for the AMETEK MCI RTP1400 Blower

Two sets of procedures are included in Chapter 4:

- Disassembling the Blower
- Reassembling the Blower

Chapter 2: Recommended Maintenance

INTRODUCTION

The primary advantage to using brushless DC impeller-style blowers is the life-cycle cost savings with regard to maintenance. Should the motor fail, it must be replaced as a unit. It cannot be disassembled and nonworking parts replaced. All other parts that comprise the AMETEK MCI RTP1400 Blower can be removed and replaced as needed.

Chapter 3: Troubleshooting

INTRODUCTION

When using the AMETEK MCI RTP1400 Blower, you may encounter one or more of the following problems:

- Locked impeller
- Over temperature shutdown (internal temperature greater than 110° C)
- Under voltage shutdown (less than 11.0 VDC)

The sections below tell you how to troubleshoot, find the cause of the problem you are experiencing and fix the problem.

LOCKED IMPELLER

If the impeller is not rotating and appears to be locked, refer to the following sections to determine whether the motor has failed or an obstruction has impeded movement of the impeller.

Motor Not Operating

If the motor is not operating, follow the steps below to determine the cause:

1. **Incorrect Voltage Connections.** Check the connections to the motor terminals to verify that the motor leads are connected to the proper supply voltage according to the hookup settings shown in table 3.1 (p. 3-2).

Operation	Red (+)	Black
High Speed	+ 27.6 VDC	Ground (-)

If the leads are reversed, the unit will not operate. A reversed connection will short the power source. Check the polarity of the connection to the bus wiring.



The series-protection device allows power to be supplied by the closure of a “fast-acting” connector, relay or similar device to ensure that the blower will start. AMETEK recommends the use of a series fuse or a fast-acting circuit breaker large enough to protect the wiring and electronics of the device needing circuit/fuse protection.

Correct the voltage-connection error. Normal blower operation should begin when the connection error has been corrected and the protection device reset.

2. **Improper Voltage.** Check the motor connections with a voltmeter to verify that the proper voltage is being supplied to the motor.

3. **Faulty Motor.** If the motor is receiving the proper voltage and still does not operate, the problem likely is with the motor. Replace the motor, and try the blower again.

Obstruction

If an obstruction is impeding the rotation of the impeller, disassemble the blower (see chapter 4), and attempt to clear the obstruction. After the obstruction has been cleared, try the blower again.

OVER TEMPERATURE SHUTDOWN

The blower may be malfunctioning because it has overheated. This means that the blower's internal temperature is greater than 110° C, the temperature at which the blower's internal thermostat is set. Normal operating temperature ranges from -40° C to 70° C (see figure 3.1, p. 3-4). Normal operation should resume when the blower's internal temperature drops to within the range for normal functioning.

UNDER VOLTAGE SHUTDOWN

The blower may be malfunctioning because the voltage supplied is less than 11.0 VDC, which is the absolute minimum voltage required for normal operation. Optimal voltage is 27.6 VDC. Intermittent voltage should be in the range of 18 VDC to 32 VDC.

Check the motor connections with a voltmeter to verify that the proper voltage is being supplied to the motor. Adjust the voltage as needed, and try the blower again. If the motor is receiving the proper voltage and still does not operate, the problem likely is with the motor. Replace the motor, and try the blower again.

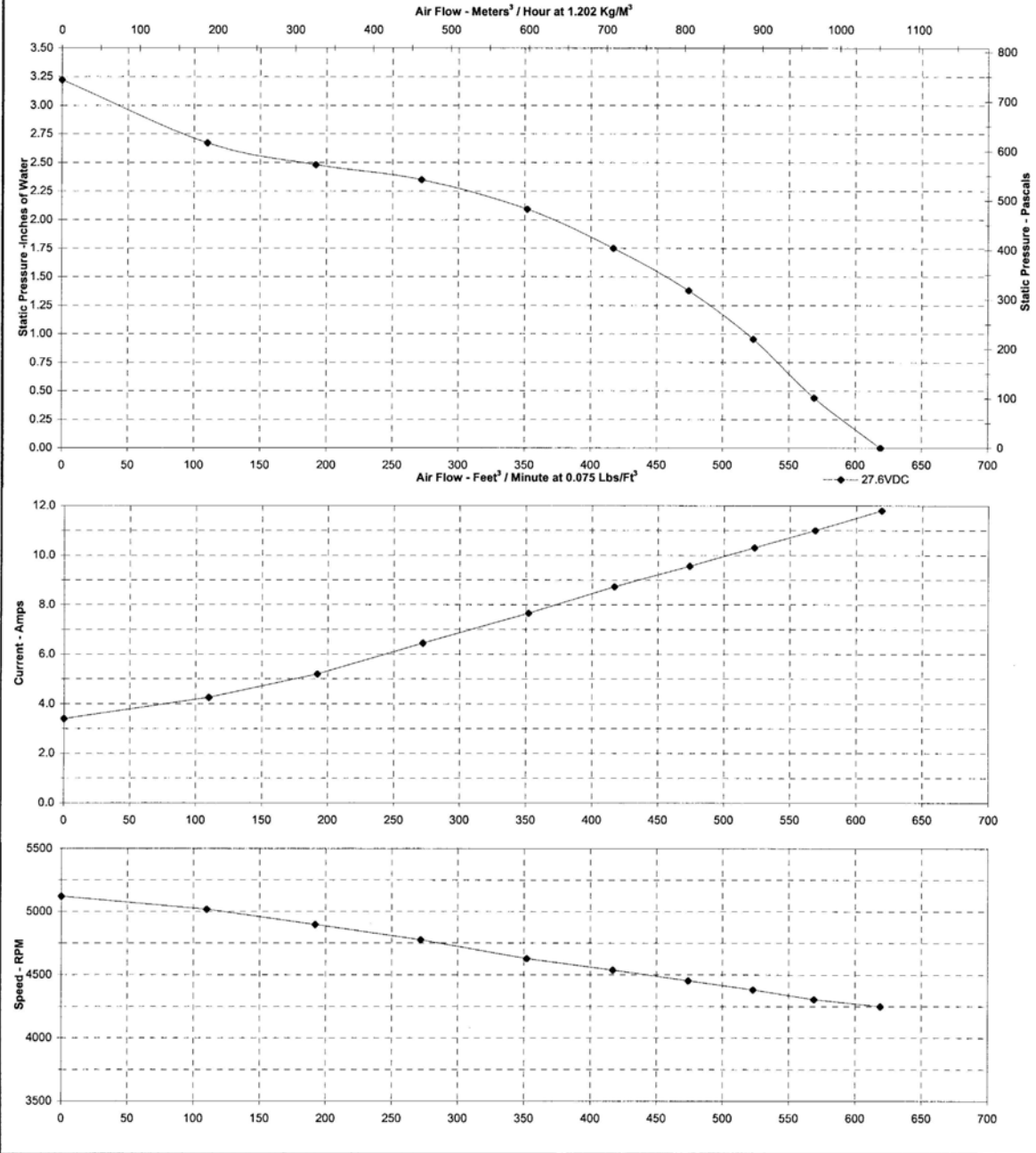

This document is for informal purposes only and should not be considered as a binding description of the products or their performance in all applications. The performance data on this page depicts typical performance under controlled laboratory conditions using AMETEK BLDC motor controllers. Actual performance will vary depending on the operating environment and application. Ametek Rotron products are not designed for and should not be used in medical and life support applications. Ametek reserves the right to revise its products without notification.

Figure 3.1 Performance Curves for the AMETEK MCI RTP1400 Blower.

Chapter 4: Maintenance and Repair Procedures

INTRODUCTION

This chapter provides step-by-step instructions for disassembling and re-assembling the AMETEK MCI RTP1400 Blower. Disassemble the unit as much as needed to replace the failed part. Note, however, that the blower motor cannot be disassembled and repaired. If the motor fails, a new one is required.

DISASSEMBLING THE BLOWER

To disassemble the AMETEK MCI RTP1400 Blower, follow the steps below, and refer to figure 4.1 (p. 4-3) for an outline drawing of the blower:

1. Disconnect the blower connector from the bus voltage supply.
2. Remove the blower-mounting hardware connecting the blower to the mounting surface.
3. Move the blower to a clean work surface.
4. Loosen and remove the 12 Phillips head screws [5] from the top portion of the blower housing [1].
5. Remove the top portion of the blower housing [1].



The two end inlet-rings [6] may fall off when the top portion of the blower housing [1] is removed. They will be put back in place in the reassembly process (see p. 4-4)

6. Remove the two end inlet-rings [6].
7. Remove the red impeller clamp [4] from the outer end of the two impellers [2] and [7] that protrude from the flat ends of the motor [8].
8. Remove the two impellers [2] and [7].
9. Remove the two interior inlet-rings [6].
10. Remove the motor [8] from the motor-cradle area of the bottom half of the blower housing [1].

ASSEMBLE BLOWER PER DETAILS BELOW

NOTES: UNLESS OTHERWISE SPECIFIED.

1. INSTALL IMPELLER CLAMPS (ITEM 4) ON IMPELLER HUBS (ITEM 2), PRIOR TO INSTALLING IMPELLERS ON MOTOR. (1) CLAMP IS TO BE INSTALLED ON EACH IMPELLER AS SHOWN. (CLAMP INSTALLATION PLIERS ROTRON TOOL #205-8667)
2. PRESS IMPELLERS FLUSH WITH END OF SHAFT AS SHOWN. ENDS OF SHAFT MUST BE FIXTURED DURING PRESSING PROCESS TO PREVENT DAMAGE TO BEARINGS. CHECK ROTATION ARROW IMPRINTED ON CENTER WALL OF EACH IMPELLER. INSURE IMPELLERS ARE ORIENTED FOR CCW ROTATION WHEN VIEWING UNIT FROM LEAD WIRE END OF MOTOR.
3. PLACE SUB-ASSEMBLED MOTOR/IMPELLERS INTO BOTTOM BLOWER HOUSING HALF (ITEM 1) WITH (1) MOTOR GASKET (ITEM 3) BETWEEN MOTOR & MOTOR CRADLE AREA. INSURE MOTOR/IMPELLERS ARE ORIENTED FOR CCW ROTATION VIEWING LEAD END. MOTOR ASSY TO BE PLACED IN MOTOR CRADLE AREA WITH LEAD WIRE GROMMET AT APPROXIMATELY 12:00 O'CLOCK AS SHOWN. NOTE THAT WHEN THE MOTOR ASSY IS CENTERED WITHIN THE BLOWER THE GROMMET WILL BE POSITIONED NEAR THE CRADLE AREA SIDEWALL.

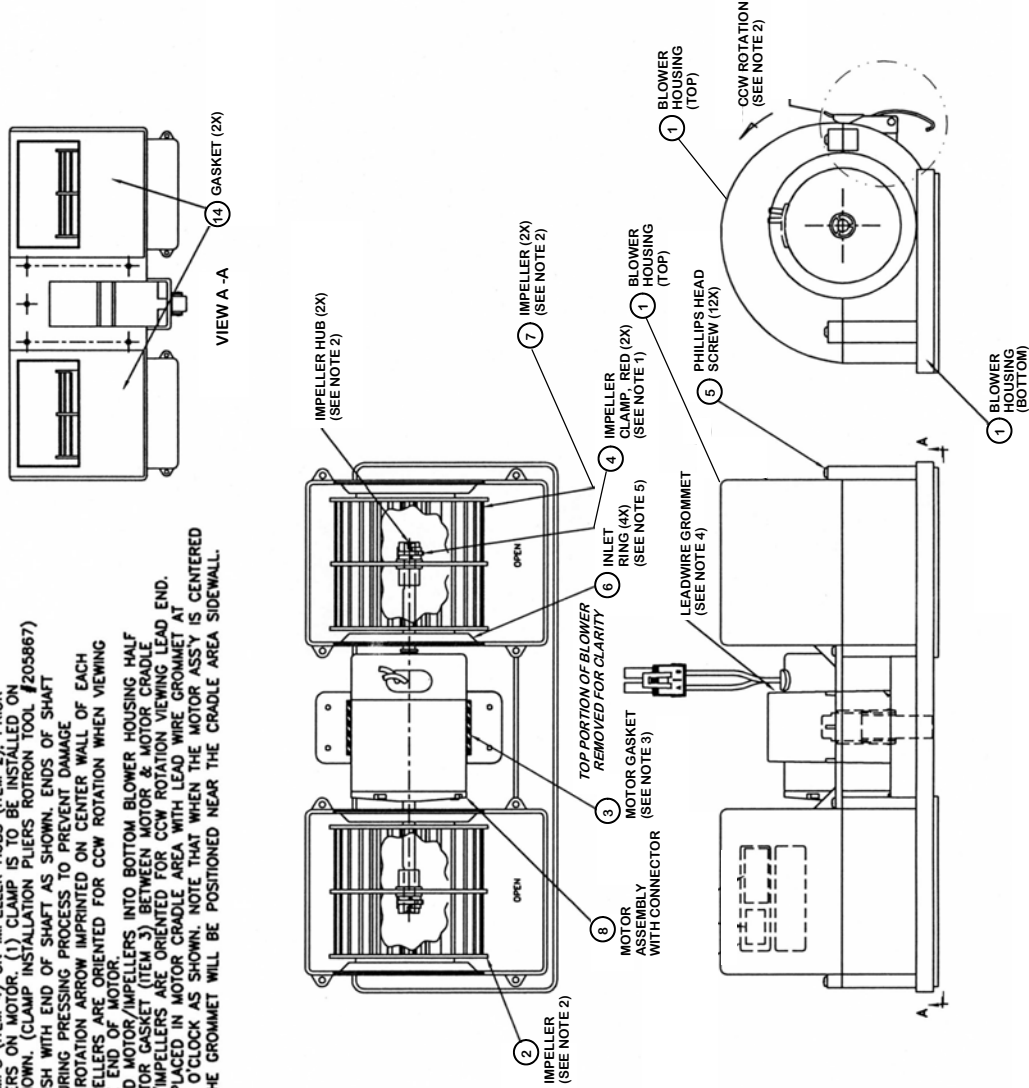

CONTROL CHARACTERISTICS MOTOR-M199-MAJOR REF. ENG. SPEC. 6-1	
THIS DRAWING AND THE INFORMATION CONTAINED HEREIN ARE THE PROPERTY OF AMETEK. IT IS TO BE USED ONLY FOR THE PURPOSES SPECIFIED AND IS NOT TO BE REPRODUCED OR TRANSMITTED IN ANY FORM OR BY ANY MEANS, ELECTRONIC OR MECHANICAL, INCLUDING PHOTOCOPYING, RECORDING, OR BY ANY INFORMATION STORAGE AND RETRIEVAL SYSTEM.	
ENGINEERING AND TOLERANCES IN ACCORDANCE WITH MIL-STD-189	
DO NOT SCALE DRAWING	TOLERANCES
UNLESS OTHERWISE SPECIFIED	XX TOLERANCES
MILITARY DRAWING STANDARDS	AS APPLIED
AMETEK DRAWING CODES: JMW/ABP	6.02 & 6.010
DATE	REVISED
SCALE: 25:1	DATE: 7/55/11
DESIGNED BY: JMW	DATE: 10/27/09
DRAWN BY: JMW	DATE: 4-21-09
CHECKED BY: JMW	DATE: 3-18-09
APPROVED BY: JMW	DATE: 3-18-09
DUPLIX BLOWER ASSEMBLY, 27VDC 3" INTERNAL DRIVE MOTOR	
AMETEK	
SHEET NO. 1 OF 1	
DRAWN BY: JMW	
DATE: 10/27/09	
TITLE: BLOWER ASSY	

Figure 4.1. Outline Drawing for the AMETEK MCI RTP1400 Blower.

REASSEMBLING THE BLOWER

To reassemble the AMETEK MCI RTP1400 Blower, follow the steps below, and refer to figure 4.1 (p. 4-3) for an outline drawing of the blower:

1. Place one of the two red impeller clamps [4] onto each of the impeller hubs, and tighten with pliers.



Put the impeller clamps [4] on the impeller hubs **before** installing the impellers on the motor.

2. Install the two interior inlet rings [6] onto the motor shaft prior to installing the impellers [2] and [7].
3. Press each impeller [2] and [7] flush with the end of the motor shaft.



The ends of motor shaft **must** be fixtured during the pressing process to prevent damage to the bearings.

4. Check the rotation arrow imprinted on the center wall of each impeller [2] and [7]. The impellers [2] and [7] should be oriented for **counterclockwise** rotation when viewed from the lead-wire end of the motor [8].
5. Place the partially assembled motor/impellers [8]/[2] and [7] into the bottom half of the blower housing [1] with the motor gasket [3] between the motor [8] and the motor-cradle area.



Ensure that motor/impellers [8]/[2] and [7] are oriented for **counterclockwise** rotation when viewed from the lead-wire end of the motor [8].

6. With the motor/impellers [8]/[2] and [7] resting in the motor-cradle area, orient the lead-wire grommet at approximately 12 o'clock as shown in the middle and bottom drawings of figure 4.1 (p. 4-3).



When the motor/impellers [8]/[2] and [7] are centered within the bottom blower housing [1], the grommet will be positioned **near** the side wall of the motor-cradle area.

7. Fit the edge of each of the four inlet rings [6] into the groove on the bottom blower housing [1].
8. Place the top portion of the blower housing [1] on top of the bottom portion of the blower housing [1], lining up the screw holes on the top and bottom halves.
9. Insert the 12 Phillips head screws [5] that secure the top and bottom portions of the blower housing [1], and torque each to 22 to 24 inch-pounds.

**Appendix A:
Replacement Parts List
for the AMETK MCI
RTP1400 Blower**

Appendix A: Replacement Parts List for the AMETEK MCI RTP1400 Blower			
AMETEK Part #	Item #	Quantity	Description
150373-00	8	1	Motor Assembly with Connector
5-44360	1	1	Blower Housing with Latch (Top and Bottom Portions)
5-4012-2	2	1	Impeller
5-4012-5	3	1	Motor Gasket
5-4012-6	4	2	Impeller Clamp (Red)
5-4012-7	5	12	Phillips Head Screw (#6, Hi-Lo)
5-4012-4	6	4	Inlet Ring
5-4012-9	7	1	Impeller
5-5497	14	2	Gasket

**Appendix B:
Specifications Outline Drawing
for the AMETEK MCI
RTP1400 Blower**

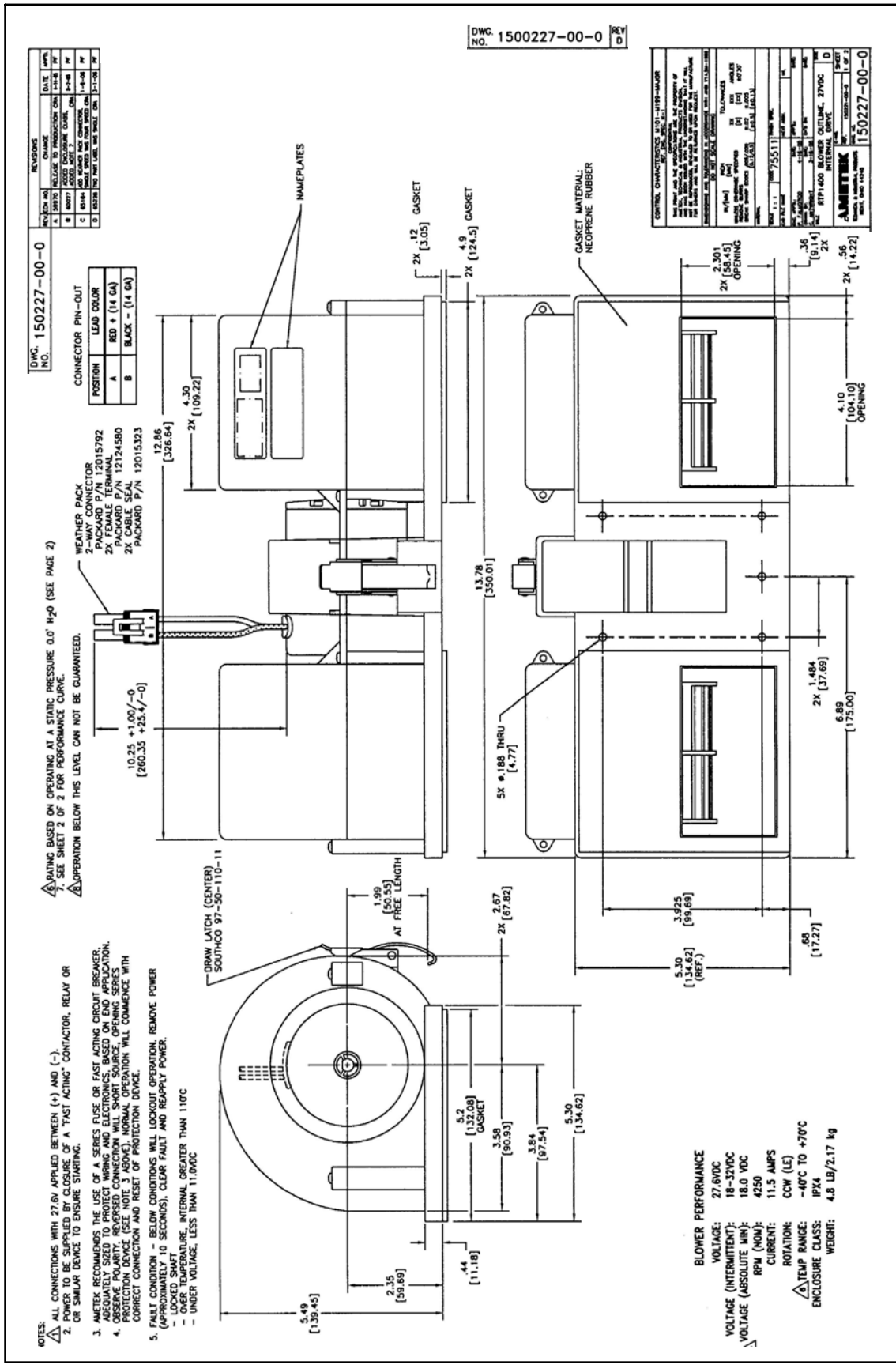

Figure B.1. Specifications Outline Drawing for the AMETEK MCI RTP1400 Blower.