

# SERVICE AND PARTS MANUAL FOR BLOWER MODEL

## DR454RD – DR656RDNT

### REMOTE DRIVE REGENERATIVE BLOWER

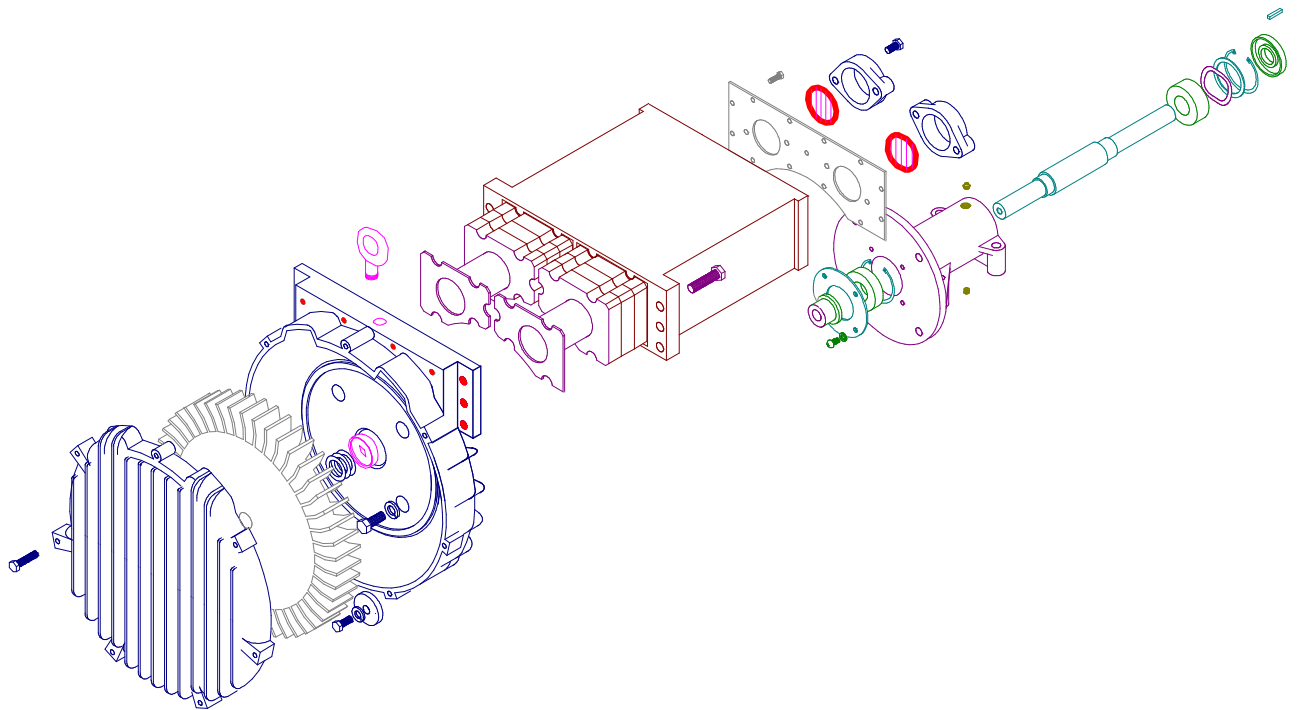

AMETEK Dynamic Fluid Solutions  
100 East Erie St., Kent, Ohio 44240  
Telephone: 330-673-3452 Fax: 330-677-3306  
email: [dfs.information@ametek.com](mailto:dfs.information@ametek.com)  
internet: [www.ametekdfs.com](http://www.ametekdfs.com)

**AMETEK**

**Your Choice. Our Commitment.™**

# WARRANTY, INSTALLATION, MAINTENANCE AND TROUBLESHOOTING INSTRUCTIONS



AMETEK Dynamic Fluid Solutions  
100 East Erie St., Kent, Ohio 44240  
Telephone: 330-673-3452 Fax: 330-677-3306  
email: [dfs.information@ametek.com](mailto:dfs.information@ametek.com)  
internet: [www.ametekdfs.com](http://www.ametekdfs.com)

1. AMETEK Rotron DR, EN and HiE regenerative direct drive blowers are guaranteed for one full year from the date of installation (limited to 18 months from the date of shipment) to the original purchaser only. Should the blower fail we will evaluate the failure. If failure is determined to be workmanship or material defect related, we will at our option repair or replace the blower.
2. AMETEK Rotron Minispiral, Revaflow, Multiflow, Nautilair, remote drive blowers, moisture separators, packaged units, CP blowers, Nasty Gas™ models and special built (EO) products are guaranteed for one full year from date of shipment for workmanship and material defect to the original purchaser only. Should the blower fail, If failure is determined to be workmanship or material defect related, we will at our option repair or replace the blower.
3. **Parts Policy** - AMETEK Rotron spare parts and accessories are guaranteed for three months from date of shipment for workmanship and material defect to the original purchaser only. If failure is determined to be workmanship or material defect related we will at our option repair or replace the part.

**Corrective Action** - A written report will be provided indicating reason(s) for failure, with suggestions for corrective action. Subsequent customer failures due to abuse, misuse, misapplication or repeat offense will not be covered. AMETEK Rotron will then notify you of your options. Any failed unit that is tampered with by attempting repair or diagnosis will void the warranty, unless authorized by the factory.

**Terms and Conditions** - Our warranty covers repairs or replacement of regenerative blowers only, and will not cover labor for installation, outbound and inbound shipping costs, accessories or other items not considered integral blower parts. Charges may be incurred on products returned for reasons other than failures covered by their appropriate warranty. Out-of-warranty product and in warranty product returned for failures determined to be caused by abuse, misuse, or repeat offense will be subject to an evaluation charge. Maximum liability will in no case exceed the value of the product purchased. Damage resulting from mishandling during shipment is not covered by this warranty. It is the responsibility of the purchaser to file claims with the carrier. Other terms and conditions of sale are stated on the back of the order acknowledgement.

## Installation Instructions for SL, DR, EN, CP, and HiE Series Blowers

1. **Bolt It Down** - Any blower must be secured against movement prior to starting or testing to prevent injury or damage. The blower does not vibrate much more than a standard electric motor.
2. **Filtration** - All blowers should be filtered prior to starting. Care must be taken so that no foreign material enters the blower. If foreign material does enter the blower, it could cause internal damage or may exit at extremely high velocity.

Should excessive amounts of material pass through the blower, it is suggested that the cover(s) and impeller(s) be removed periodically and cleaned to avoid impeller imbalance. Impeller

imbalance greatly speeds bearing wear, thus reducing blower life. Disassembling the blower will void warranty, so contact the factory for cleaning authorization.

- Support the Piping** - The blower flanges and nozzles are designed as connection points only and are not designed to be support members.

Caution: Plastic piping should not be used on blowers larger than 1 HP that are operating near their maximum pressure or suction point. Blower housing and nearby piping temperatures can exceed 200°F. Access by personnel to the blower or nearby piping should be limited, guarded, or marked, to prevent danger of burns.

- Wiring** - Blowers must be wired and protected/fused in accordance with local and national electrical codes. All blowers must be grounded to prevent electrical shock. Slo-Blo or time delay fuses should be used to bypass the first second of start-up amperage.
- Pressure/Suction Maximums** - The maximum pressure and/or suction listed on the model label should not be exceeded. This can be monitored by means of a pressure or suction gage (available from Rotron), installed in the piping at the blower outlet or inlet. Also, if problems do arise, the Rotron Field representative will need to know the operating pressure/suction to properly diagnose the problem.
- Excess Air** - Bleed excess air off. DO NOT throttle to reduce flow. When bleeding off excess air, the blower draws less power and runs cooler.

**Note:** Remote Drive (Motorless) Blowers - Properly designed and installed guards should be used on all belts, pulleys, couplings, etc. Observe maximum remote drive speed allowable. Due to the range of uses, drive guards are the responsibility of the customer or user. Belts should be tensioned using belt gauge.

Maintenance Procedure

**When properly piped, filtered, and applied, little or no routine maintenance is required. Keep the filter clean. Also, all standard models in the DR, EN, CP, and HiE series have sealed bearings that require no maintenance. Bearing should be changed after 15,000 to 20,000 hours, on average. Replacement bearing information is specified on the chart below.**

Bearing Part Number	Size	Seal Material	Grease	Heat Stabilized
510217 510218 510219	205 206 207	Polyacrylic	Nye Rheotemp 500 30% +/- 5% Fill	Yes – 325 F
510449 516440 516648	203 202 307	Buna N	Exxon Polyrex Grease	NO
516840 516841 516842 516843 516844 516845 516846 516847	206 207 208 210 309 310 311 313	Buna N	Exxon Polyrex Grease	NO

## Troubleshooting

		POSSIBLE CAUSE	OUT OF WARRANTY REMEDY ***
IMPELLER DOES NOT TURN	Humming Sound	<ol style="list-style-type: none"> <li>* One phase of power line not connected</li> <li>* One phase of stator winding open</li> <li>Bearings defective</li> <li>Impeller jammed by foreign material</li> <li>Impeller jammed against housing or cover</li> <li>** Capacitor open</li> </ol>	<ol style="list-style-type: none"> <li>Connect</li> <li>Rewind or buy new motor</li> <li>Change bearings</li> <li>Clean and add filter</li> <li>Adjust</li> <li>Change capacitor</li> </ol>
	No Sound	<ol style="list-style-type: none"> <li>* Two phases of power line not connected</li> <li>* Two phases of stator winding open</li> </ol>	<ol style="list-style-type: none"> <li>Connect</li> <li>Rewind or buy new motor</li> </ol>
IMPELLER TURNS	Blown Fuse	<ol style="list-style-type: none"> <li>Insufficient fuse capacity</li> <li>Short circuit</li> </ol>	<ol style="list-style-type: none"> <li>Use time delay fuse of proper rating</li> <li>Repair</li> </ol>
	Motor Overheated Or Protector Trips	<ol style="list-style-type: none"> <li>High or low voltage</li> <li>* Operating in single phase condition</li> <li>Bearings defective</li> <li>Impeller rubbing against housing or cover</li> <li>Impeller or air passage clogged by foreign material</li> <li>Unit operating beyond performance range</li> <li>Capacitor shorted</li> <li>* One phase of stator winding short circuited</li> </ol>	<ol style="list-style-type: none"> <li>Check input voltage</li> <li>Check connections</li> <li>Check bearings</li> <li>Adjust</li> <li>Clean and add filter</li> <li>Reduce system pressure/vacuum</li> <li>Change capacitor</li> <li>Rewind or buy new motor</li> </ol>
	Abnormal Sound	<ol style="list-style-type: none"> <li>Impeller rubbing against housing or cover</li> <li>Impeller or air passages clogged by foreign material</li> <li>Bearings defective</li> </ol>	<ol style="list-style-type: none"> <li>Adjust</li> <li>Clean and add filter</li> <li>Change bearings</li> </ol>
	Performance Below Standard	<ol style="list-style-type: none"> <li>Leak in piping</li> <li>Piping and air passages clogged</li> <li>Impeller rotation reversed</li> <li>Leak in blower</li> <li>Low voltage</li> </ol>	<ol style="list-style-type: none"> <li>Tighten</li> <li>Clean</li> <li>Check wiring</li> <li>Tighten cover, flange</li> <li>Check input voltage</li> </ol>
<p>* 3 phase units  ** 1 phase units  *** Disassembly and repair of new blowers or motors will void the Rotron warranty. Factory should be contacted prior to any attempt to field repair an in-warranty unit.</p>			

### **Blower Disassembly:**

**WARNING:** Attempting to repair or diagnose a blower may void Rotron's warranty. It may also be difficult to successfully disassemble and reassemble the unit.

- 1) Disconnect the power leads. **CAUTION:** Be sure the power is disconnected before doing any work whatsoever on the unit.
- 2) Remove or separate piping and/or mufflers and filters from the unit.
- 3) Remove the cover bolts and then the cover. **NOTE:** Some units are equipped with seals. It is mandatory that these seals be replaced once the unit has been opened.
- 4) Remove the impeller bolt and washers and then remove the impeller. **NOTE:** Never pry on the edges of the impeller. Use a puller as necessary.
- 5) Carefully note the number and location of the shims. Remove and set them aside. **NOTE:** If the disassembly was for inspection and cleaning the unit may now be reassembled by reversing the above steps. If motor servicing or replacement and/or impeller replacement is required the same shims may not be used. It will be necessary to re-shim the impeller according to the procedure explained under assembly.

- 6) Remove the housing bolts and remove the motor assembly (arbor/housing on remote drive models).
- 7) Arbor disassembly (Applicable on remote drive models only):
  - a) Slide the bearing retraining sleeve off the shaft at the blower end.
  - b) Remove the four (4) screws and the bearing retaining plate from the blower end.
  - c) Lift the shaft assembly far enough out of the arbor to allow removal of the blower end snap ring.
  - d) Remove the shaft assembly from the arbor.
  - e) If necessary, remove the shaft dust seal from the pulley end of the arbor.

*Muffler Material Replacement:*

- 1) Remove the manifold cover bolts and them manifold cover.
- 2) The muffler material can now be removed and replaced if necessary. On blowers with fiberglass acoustical wrap the tubular retaining screens with the fiberglass matting before sliding the muffler pads over the screens.
- 3) Reassemble by reversing the procedure.

**NOTE: On DR068 models with tubular mufflers it is necessary to remove the cover and impeller accessing the muffler material from the housing cavity.**

*Blower Reassembly:*

- 1) Place the assembled motor (assembled arbor assembly for remote drive models) against the rear of the housing and fasten with the bolts and washer.
- 2) To ensure the impeller is centered within the housing cavity re-shim the impeller according to the procedure outlined below.
- 3) If blower had a seal replace the seal with a new one.
- 4) Place the impeller onto the shaft making sure the shaft key is in place and fasten with the bolt, washer and spacer as applicable. Torque the impeller bolt per the table below. Once fastened carefully rotate the impeller to be sure it turns freely.
- 5) Replace the cover and fasten with bolts.
- 6) Reconnect the power leads to the motor per the motor nameplate.

<b>Bolt Size</b>	<b>Torque Pound-Force-Foot</b>
<b>1/4-20</b>	<b>6.25 +/- 0.25</b>
<b>5/16-18</b>	<b>11.5 +/- 0.25</b>
<b>3/8-16</b>	<b>20.0 +/- 0.5</b>
<b>1/2-13</b>	<b>49.0 +/- 1</b>
<b>5/8 -11</b>	<b>90.0 +/- 2</b>

*Impeller Shimming Procedure:*

WARNING: This unit may be difficult to shim. Extreme care may be exercised.

Tools Needed: Machinist's Parallel Bar  
Vernier Caliper with depth measuring capability  
Feeler gauges or depth gauge

Measure the Following:

- Distance from the flange face to the housing (A)
- Distance from the flange face to the motor shaft shoulder (B)
- Impeller Thickness (C)

Measurements (A) and (B) are made by laying the parallel bar across the housing flange face and measuring to the proper points. Each measurement should be made at three points, and the average of the readings should be used.

$$\text{Shim Thickness} = B - (A+C)/2$$

After the impeller installation (step #4 above) the impeller/cover clearance can be checked with feeler gauges, laying the parallel bar across the housing flange face. This clearance should nominally be (A-C)/2.

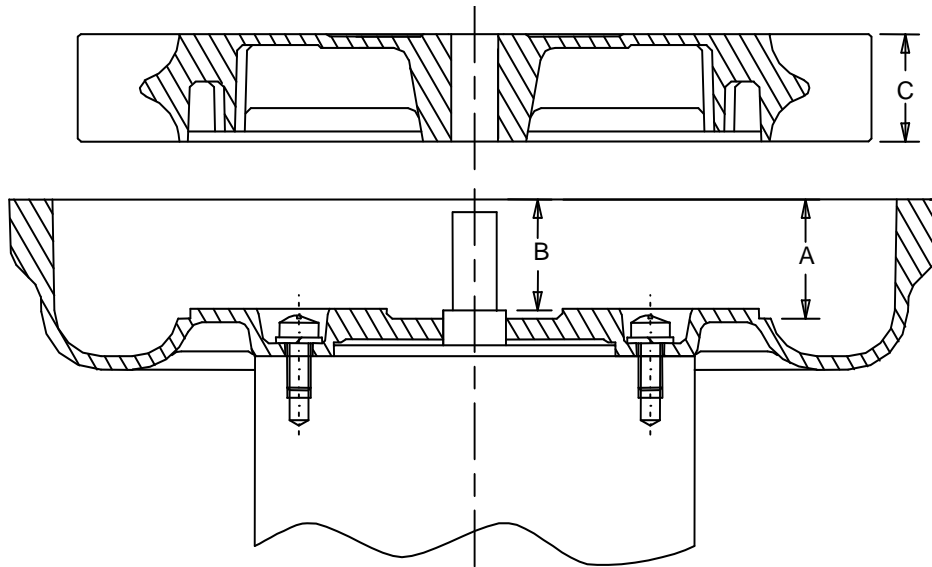

# ASSEMBLY DRAWING DR454 DR505 DR513 DR555 DR606 DR656 REMOTE DRIVE BLOWERS

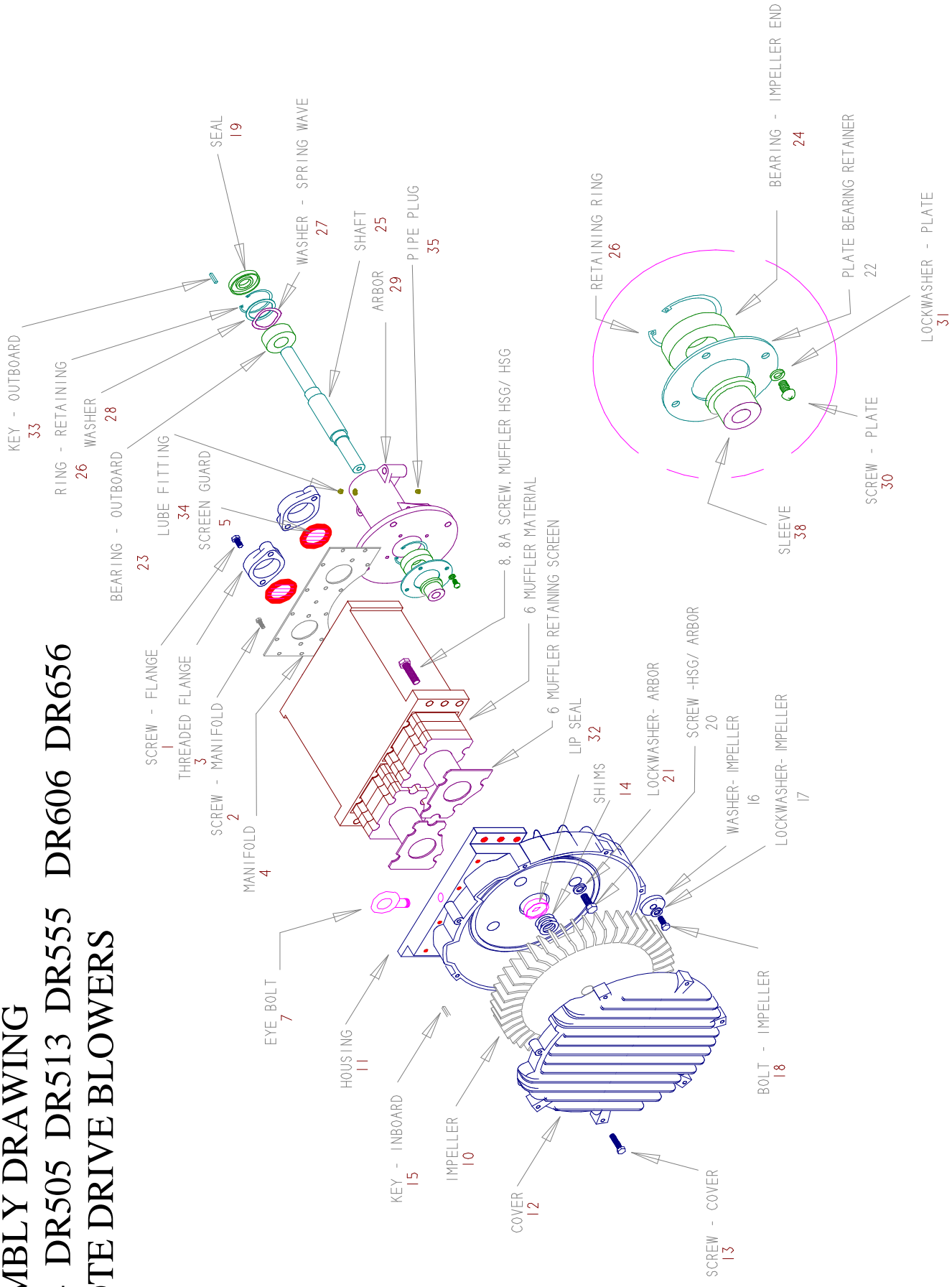

**Remote Drive 454/505/513/555/606/656  
Service and Parts Manual**

**Parts Breakdown**

Model:

Part No.:

DR454RD  
038201

DR454RDNT  
080489

DR505RD  
**038204**  
**OBSOLETE**  
036437

DR513RD  
038197  
038076  
038076

DR555RD  
038198

DR606RDM  
**038541**  
**OBSOLETE**  
038542

Current models ----->

Item No.	Qty. Req'd	Description	120162	120162	120162	120162	120162	120162	120162	120065
1	4	Screw, Flange	120162	120162	120162	120162	120162	120162	120162	120065
2	6	Screw, Manifold	155496	155170 (10 pcs)	120214	155496	155496	155496	155496	155496
3	2	Flange	510354	510354	510354	510354	510354	510354	510354	See Next Page
4	1	Manifold	516410	516410	517460	529868	517460	517460	516392	516392
5		Screen Guard	Not Used	Not Used	Not Used	Not Used	Not Used	Not Used	Not Used	Not Used
6	4	Muffler Material	515743	Not Used	Not Used	Not Used	515743	515743	515743	See Next Page
	1	Screen, Muffler Retaining, Right (**)	510362	Not Used	Not Used	Not Used	Not Used	510362	510362	See Next Page
	1	Screen, Muffler Retaining, Left (**)	510362	Not Used	Not Used	Not Used	Not Used	510362	510362	See Next Page
7		Eyebolt	Not Used	Not Used	Not Used	Not Used	Not Used	Not Used	Not Used	529781
8		Screw, Muffler Hsg/Hsg	Not Used	Not Used	Not Used	Not Used	Not Used	Not Used	Not Used	529782
8A		Screw, Muffler Hsg/Hsg	Not Used	Not Used	Not Used	Not Used	Not Used	Not Used	Not Used	529782
10	1	Impeller	515675	551067	517433	See Next Page	516678	516678	516678	511272
11	1	Housing	551332	551410	See Next Page	See Next Page	529210	529210	529210	See Next Page
12	1	Cover	515702	551065	517431	516559	516675	516675	516675	511274
13	6	Screw, Cover	155236	155129	155236 (8 pcs)	155236 (7 pcs)	155236	155236	155236	155236
14	*	Shim .002"	510356	510356	510356	510356	510356	510356	510356	510356
	*	Shim .005"	510357	510357	510357	510357	510357	510357	510357	510357
	*	Shim .010"	510358	510358	510358	510358	510358	510358	510358	510358
	*	Shim .020"	510359	510359	510359	510359	510359	510359	510359	510359
	*	Shim .030"	Not Used	Not Used	Not Used	Not Used	Not Used	Not Used	Not Used	Not Used
15	1	Key, Shaft Inboard	510629	510629	510629	510629	510629	510629	510629	510629
16	1	Washer Flat Impeller	510355	510355	510355	510355	510355	510355	510355	510355
17	1	Lockwasher Impeller	120203	120203	120203	120203	120203	120203	120203	120203
18	1	Bolt, Impeller	120214	120214	120214	120325	120262	120262	120262	See Next Page
		Spacer, Shaft/Impeller	Not Used	Not Used	Not Used	Not Used	Not Used	Not Used	Not Used	Not Used
19	1	Seal, Shaft/Arbor	511446	511446	511446	511446	511446	511446	511446	511446
	1	Retainer Seal	511440	511440	511440	511440	511440	511440	511440	511440
20	4	Screw, Hsg/Arbor	251791	251791	251791	251791	251791	251791	251791	251791
21	4	Lockwasher, Hsg/Arbor	251787	251787	251787	251787	251787	251787	251787	251787
22	1	Plate, Bearing Retainer	511442	511442	511442	511442	511442	511442	511442	511442
23	1	Bearing Outboard	529191	529191	529191	529191	529191	529191	529191	529191
24	1	Bearing, Impeller End	510217	510217	510217	510217	510217	510217	510217	510217
25	1	Shaft	511444	511444	511444	511444	511444	511444	511444	511444
26	2	Ring Retainer	140004	140004	140004	140004	140004	140004	140004	140004
27	1	Washer, Wave Spring	120247	120247	120247	120247	120247	120247	120247	120247
28		Washer	Not Used	Not Used	Not Used	Not Used	Not Used	Not Used	Not Used	Not Used
29	1	Arbor	511434	511434	511434	511434	511434	511434	511434	511434

\*As needed \*\*Viewed looking at inlet/outlet ports



**Remote Drive 454/505/513/555/606/656  
Service and Parts Manual**

**Parts Breakdown**

Model:

Part No.:

DR454RD 038201	DR454RDNT 080489	DR505RD <b>038204</b> <b>OBSOLETE</b>	DR513RD 038197 038076 038076	DR555RD 038198	DR606RDM <b>038541</b> <b>OBSOLETE</b>
		036437			038542

Current models ----->

Item No.	Qty.	Req'd	Description	251207	251207	251207	251207	251207	251207
30	4		Screw, Plate	140009	140009	140009	140009	140009	140009
31	4		Lockwasher, Plate	Not Used	Not Used	Not Used	Not Used	Not Used	Not Used
32			Lip Seal, Shaft/Hsg	511443	511443	511443	511443	511443	511443
33	1		Key, Shaft Outboard	Not Used	Not Used	Not Used	Not Used	Not Used	Not Used
34			Lube Fitting	Not Used	Not Used	Not Used	Not Used	Not Used	Not Used
35			Pipe Plug	Not Used	Not Used	Not Used	Not Used	Not Used	Not Used
36			Heat Slinger Assembly	Not Used	Not Used	Not Used	Not Used	Not Used	Not Used
38	1		Sleeve, Bearing Retainer	511441	511441	511441	511441	511441	511441

Model	Special Parts	Model Part No.	Item No.	Item Part No.	Quantity
DR454RDM		038201			
DR454RDNT		080489			
DR505RD		038204	11	551333	1
DR505RDNT		036437	11	517466	1
DR513RD		038197	10	516557	1
			11	529209	1
DR513RDNT		038076	10	516557	1
			11	551281	1
DR606RDM		038541	3	551280	2
			6	529781	4
			6	529872	2
			11	529808	1
			18	120325	1
DR606RDNT		038542	3	511480	1 each
			5	511479	1
			6	Not Used	0
			11	529809	1
			18	155101	1
DR656RDNT		80610			

DR656RDNT  
080610

120255
(7 pcs) 155496
478341
551427
511479
Not Used
Not Used
Not Used
Not Used
Not Used
550305
551425
550249
(8 pcs) 155236
510356
510357
510358
510359
Not Used
510629
510355
120203
155101
Not Used
511446
511440
251791
Not Used
511442
529191
510217
511444
140004
120247
Not Used
511434

\*As needed \*\*Viewed looking at inlet/outlet ports

